



Rev 19

HEAVY DUTY TARGET RETRIEVAL SYSTEM

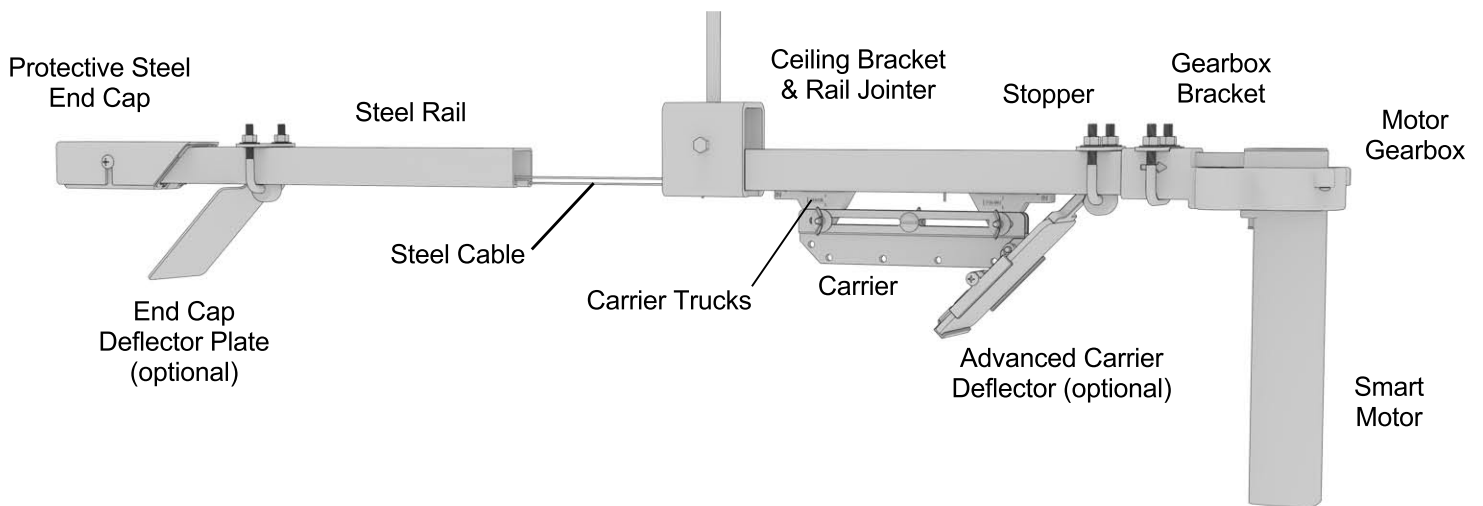
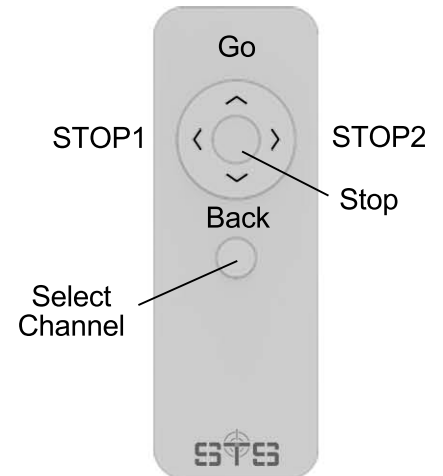
Simple & Affordable

STS is dedicated to providing the most AFFORDABLE solution for the target shooting enthusiasts eager to build their own target retrieval system. Whether that be private, home-based, or commercial. We offer complete target retrieval systems, bullet traps, target monitoring cameras, and other advanced indoor range equipment. Our solutions come with exceptional prices and quality when compared to the competition.

The new **Heavy Duty Target Retrieval System** is steel cable driven and built using common inexpensive steel strut rails. It's easy to install without the need for expensive factory assistance or highly skilled technicians. However, to ensure a successful installation, a few critical steps must be followed. Please read the following manual carefully so that your system is operating at peak performance.

Heavy Duty System Features

- Steel Rails (12GA) with SS aircraft wire
- Metal carrier with steel rollers and bullet deflector (max 9mm rated)
- Easy to install DIY kit (no need for specialized contractors)
- Inexpensive to maintain and troubleshoot
- High Speed Motor (~3ft/s) with smart technology:
 - Soft start/stop, overload protection, wirelessly controlled
- Up to 165ft capability (*longer distances available with special order*)
- Wireless controller with smart functions:
 - Programmable Limits/Stops setup
 - 2 intermediate programmable stopping points (third stop available with special controller)
- Optional Wired Controller available.





Components List (1 Lane):

Steel Rail (#TRSHD-RXX)
Qty: Varies



Stopper (#TRSX-MRS-1)
Qty: 2

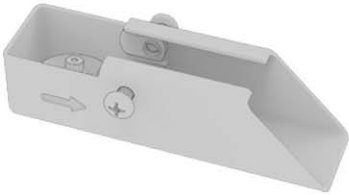
Ceiling Mount (#TRSHD-CM1)
Qty: N x Rails + 1



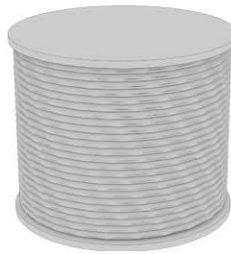
Gearbox- Motor End (#TRSHD-MG1)
Qty: 1



Gearbox- Rail End (#TRSHD-RE1)
Qty: 1



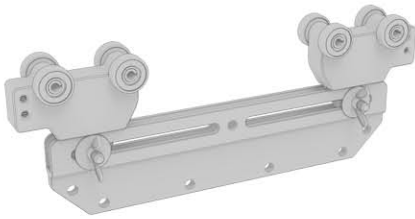
Steel Cable Spool (#TRSHD-3277-XXX)
Qty: 1 (320ft)



Motor Kit (#TRSX-93024V)
Qty: 1



Target Carrier (#TRSHD-TC1)
Qty: 1



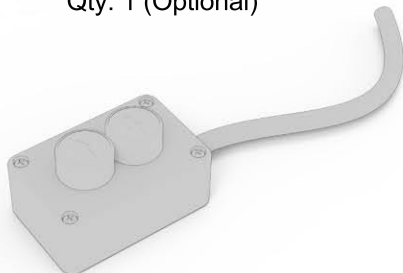
Swing Bar (#TRSX-SB10)
Qty: 1



Target Holder (#TRSX-TH2)
Qty: 1



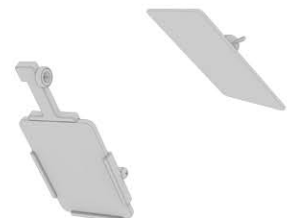
Wired Controller (#TRSX-WT1)
Qty: 1 (Optional)



Wireless Controller (#TRSX-YR1019S)
Qty: 1



Deflector Plate (#TRSX-CBD-2) Qty: 1



Advanced Deflector Plate (#TRSX-CBD-1) Qty: 1
-Optional-

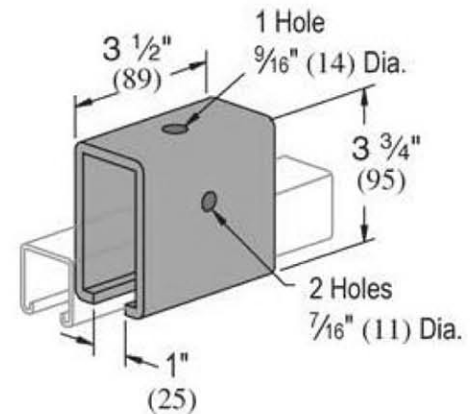
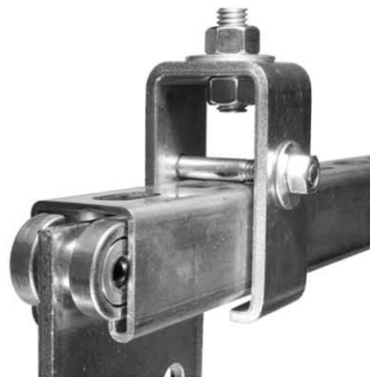
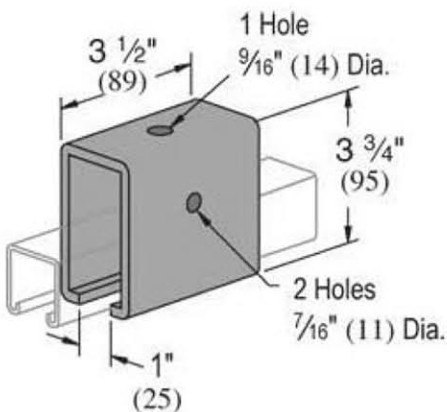
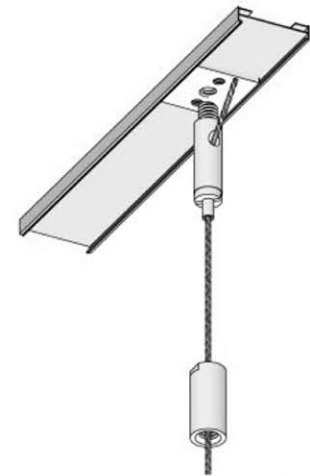
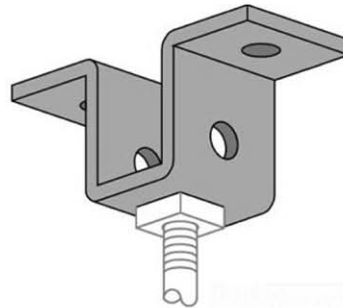
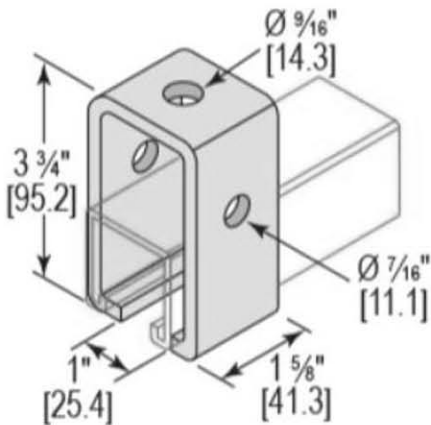


Rail Installation Notes

(Standard Strut Channel Type: 1-5/8" x 1-5/8")

- U-shaped brackets are needed to ensure clean movement of the target carrier. The Rails must be completely free of any interior obstructions.
- Verify the Rails and joint sections are not bent or damaged in any way. If they are, replace the Rail or cut out the damaged part.
- The U-shaped brackets are used to hold the Rail sections together and to suspend them from the ceiling. Tighten the U-shaped brackets to properly clamp the rails in place using the 3/8" bolts and nuts. The wider brackets are more robust, but a bit more expensive.
- When suspending the Rails, the U-shaped brackets can be used with threaded rods (or cables) and ceiling brackets. Typical rod diameter is 3/8" or 1/4" with corresponding nuts or couplers.

Rail Mounting Options



Directly on Ceiling

Using Threaded Rods

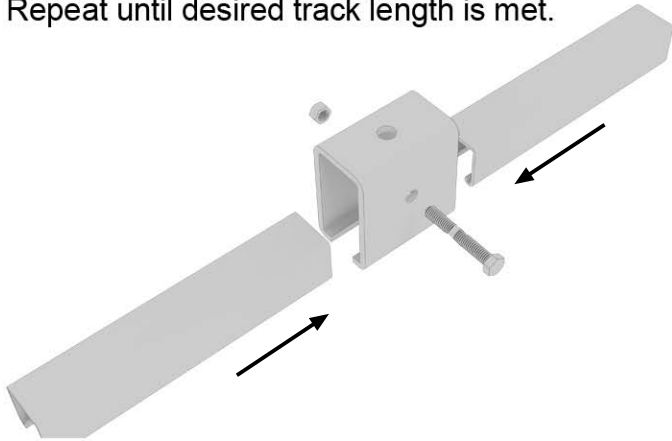
Using Suspended Cables



Installation steps

Note: Ceiling Brackets can be mounted directly to the ceiling or suspended using threaded rods or cables.

Step 1: Install Ceiling Brackets in the desired location. Install the rail segments inside the brackets and tighten using included hardware. Repeat until desired track length is met.



Step 2: Measure and cut the Steel Cable using the formula: **Total Length = 2x track length + 2ft.**

Step 3: Attach each end of the Steel Cable to one of the rolling trucks (see Fig. 1 below). The cable will thread in, down, then tighten with Allen wrench.

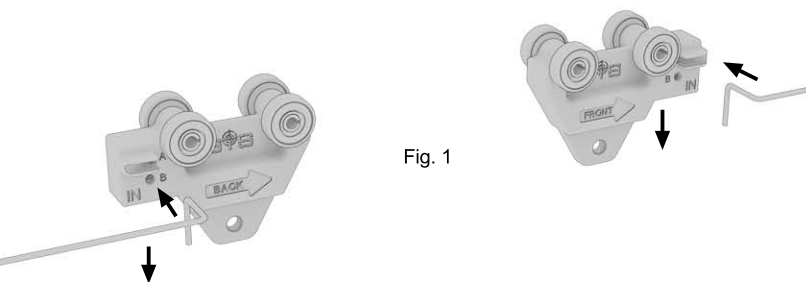


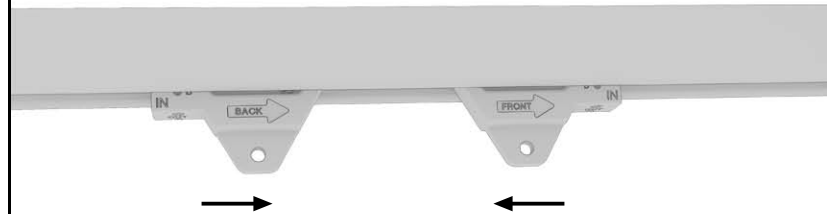
Fig. 1

IMPORTANT: The rolling trucks and Motor Gearbox each have an arrow on them. Install the trucks so that the arrows on each truck and the arrow on the Motor Gearbox cover point in the same direction (See Fig. 2).

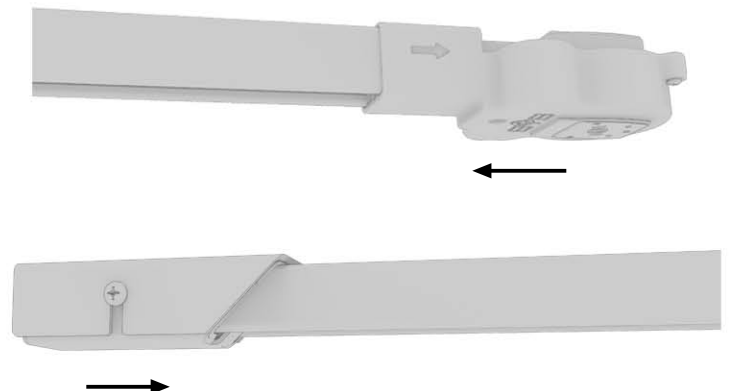


Fig. 2

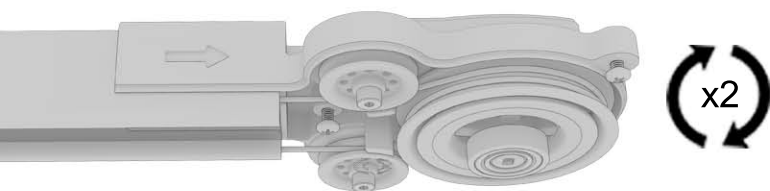
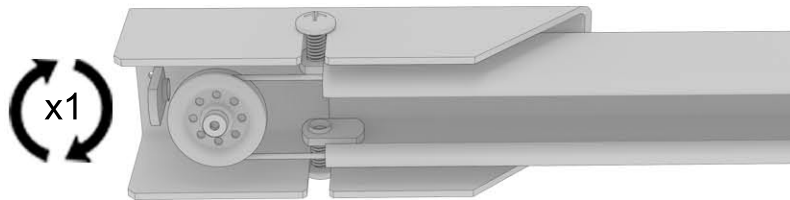
Step 4: Insert each rolling truck at the opposite end of the rails and bring them closer together to meet in the middle of the rail assembly. While performing this action make sure to avoid the cable tangling. Use Binder Clips (or something similar) to hold the cable in place onto the rail lip.



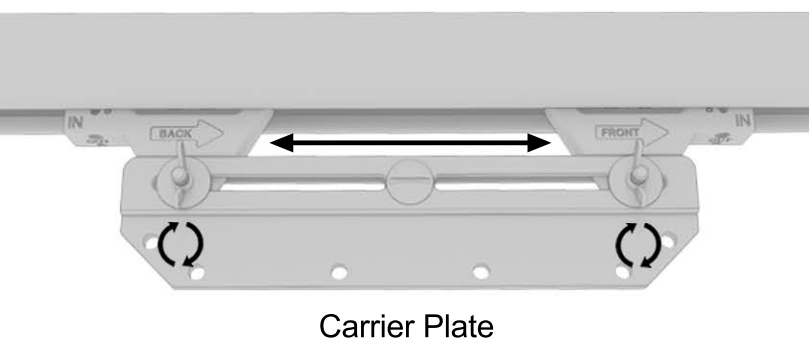
Step 5: Attach the Motor Gearbox and Rail-end Gearbox to each end of the rail assembly.



Step 6: Loop the cable around the pulleys inside the Gearboxes. Be sure to loop the cable TWICE around the Motor Gearbox and ONCE around the Rail-end Gearbox. Attach the Carrier Plate using the provided bolt/wing nuts. Loosen up the cable pinch in one of the trucks and remove the excess cable slack without cutting the extra length yet. Re-tighten the cable.

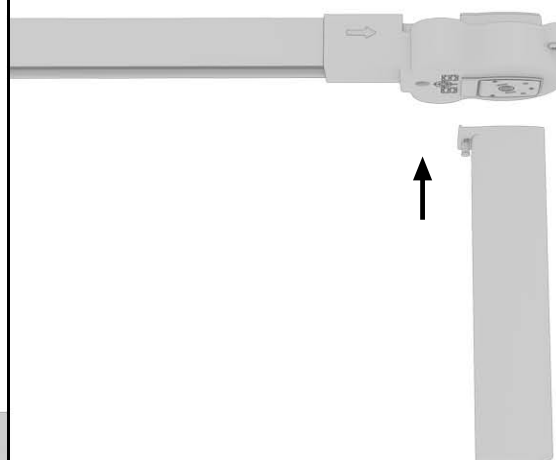


Note: Make sure wire does not overlap itself.



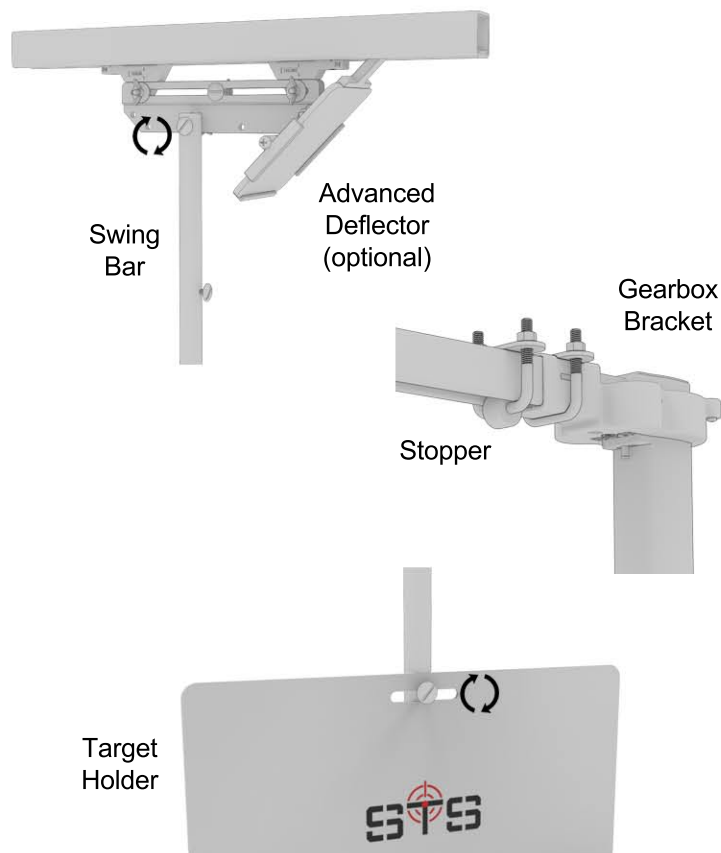
Step 7: To test proper tension, move the carrier back and forth the entire length of rail using only 1 finger. Confirm there is smooth travel by the carrier and the steel cable does not overlap itself within the Motor Gearbox.

Step 8: Install the motor (see Motor Manual for more details).



Step 9: Connect the Power Supply to the Motor and verify movement. Consult the motor manual for smoother efficient operation, setting rail limits, stopping points, etc.

Step 10: Install the Swing Bar, carrier deflector, U-shaped stopper, and Target Holder. Secure the Motor Gearbox with Gearbox Bracket similar to the Stopper Bracket.





Troubleshooting Tips

No	Issue	Solution
1	Motor does not start	Check power, check motor LED lights, then check if controller is paired properly (if wireless). Check comms cable is plugged in properly (if wired). See motor manual for details on pairing.
2	Carrier does not move	Check cable tension and reduce if necessary. Check if cable fell out of any pulleys. Try moving carrier by hand. Check LED lights on motor to make sure it receives controller's commands properly
3	Carrier stops unexpectedly.	Check for lane obstructions. Check arrows matching. Clear the motor memory of any previous stops, remove any programmable limits
4	Carrier hits hard the rail ends	Setup motor travel limits
5	Controllers GO and HOME buttons work in reverse	Change motor running direction (see manual)
6	Carrier moving too slow or bangs into rail ends even after setting travel limits	Remove the motor, move the carrier by hand and look for potential high friction spots. Check the cable around the pulleys. Check cable tension and arrows matching.

Tel: (331) 431-2621

Sales: sales@supertargetsystems.com

Tech Support: support@supertargetsystems.com

2055 Comprehensive Dr. - Aurora, IL - 60505

www.supertargetsystems.com

Thank you for your business!